

MODEL NAME LION KITCHEN

MODEL NUMBER 201010160005

Description

Shower and regular kitchen
High heat and pressure resistant ceramic
cartridge
Kitchen faucet with dual-function, sprayer
head
Water saving perlator
Less surface sedimentation due to special
body design
Fast and easy installation
Easily cleanable
Ergonomic structure
Kitchen (shower type) faucet to cover
larger washing areas
Cartridge size: 40mm
%100 QC

Scale Drawing

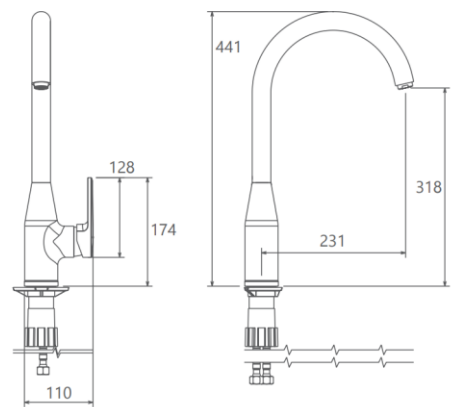

MODEL NAME LION KITCHEN

MODEL NUMBER 201010160005

Exploded Drawing

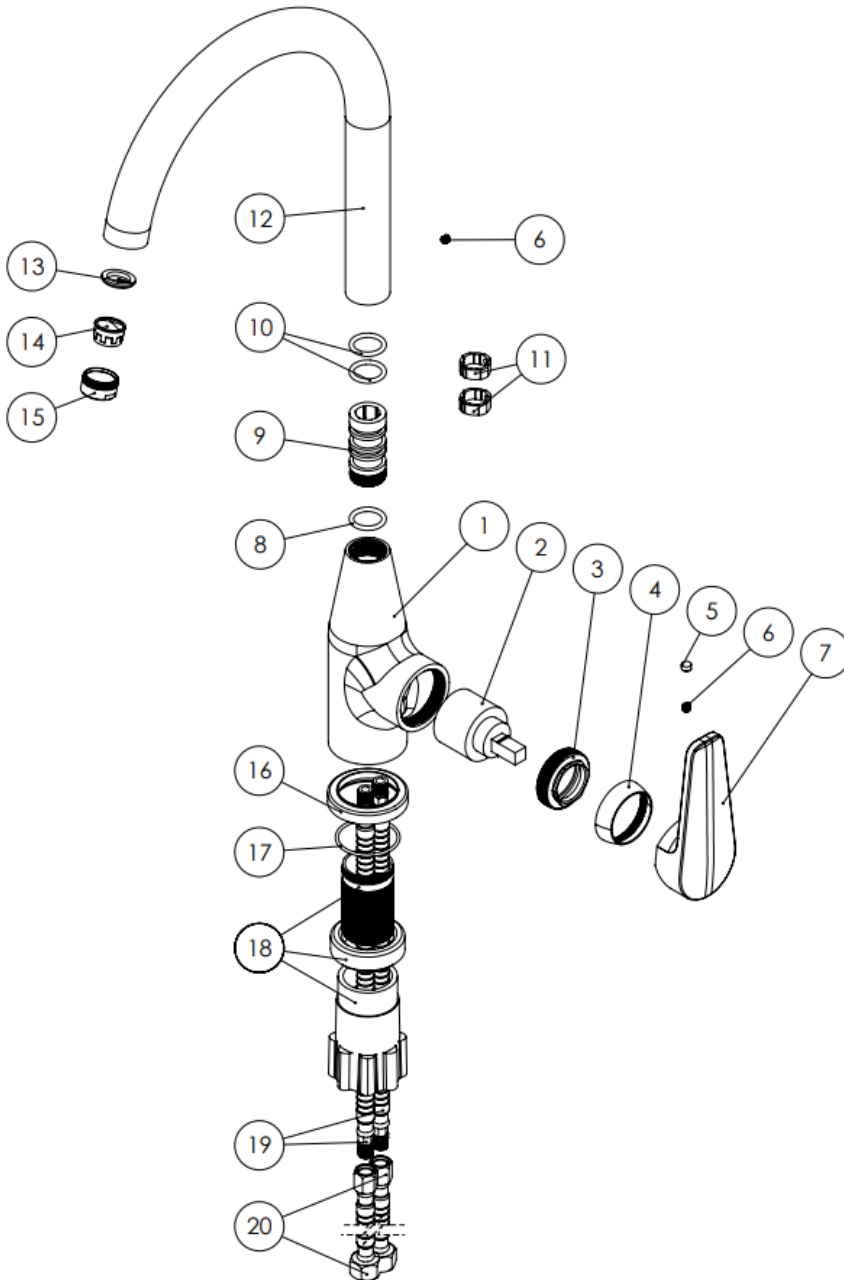

MODEL NAME LION KITCHEN**MODEL NUMBER 201010160005****Part List**

No.	Item Number	Quantity used
1	304700000258	1
2	120100000017	1
3	120100000022	1
4	121600000004	1
5	121500000003	1
6	120500000099	2
7	305700000220	1
8	120200000074	1
9	317800000044	1
10	120200000084	2
11	123800000006	2
12	318200000061	1
13	120300000025	1
14	121700000004	1
15	313700000002	1
16	306700000013	1
17	120200000086	1
18	123500000012	1
19	121000000027	2
20	121000000040	2