

MODEL NAME ATLANTIC DUAL-PURPOSE MODEL NUMBER 201100270005
KITCHEN

Description

High heat and pressure resistant ceramic cartridge
With direct connection to water treatment machine
Water saving perlator
Easily cleanable
Fast and easy installation
Ergonomic structure
Cartridge size: 35mm
%100 QC

Scale Drawing

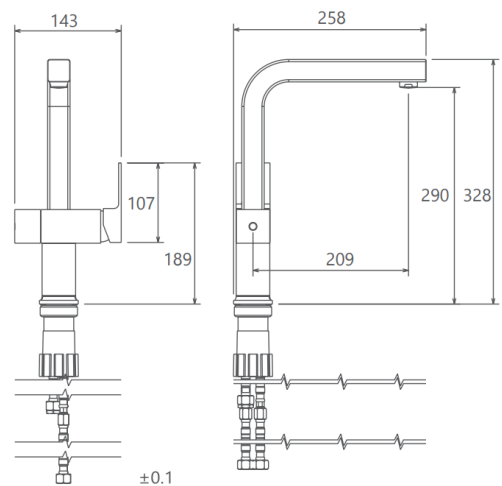

MODEL NAME ATLANTIC DUAL-PURPOSE MODEL NUMBER 201100270005
KITCHEN

Exploded Drawing

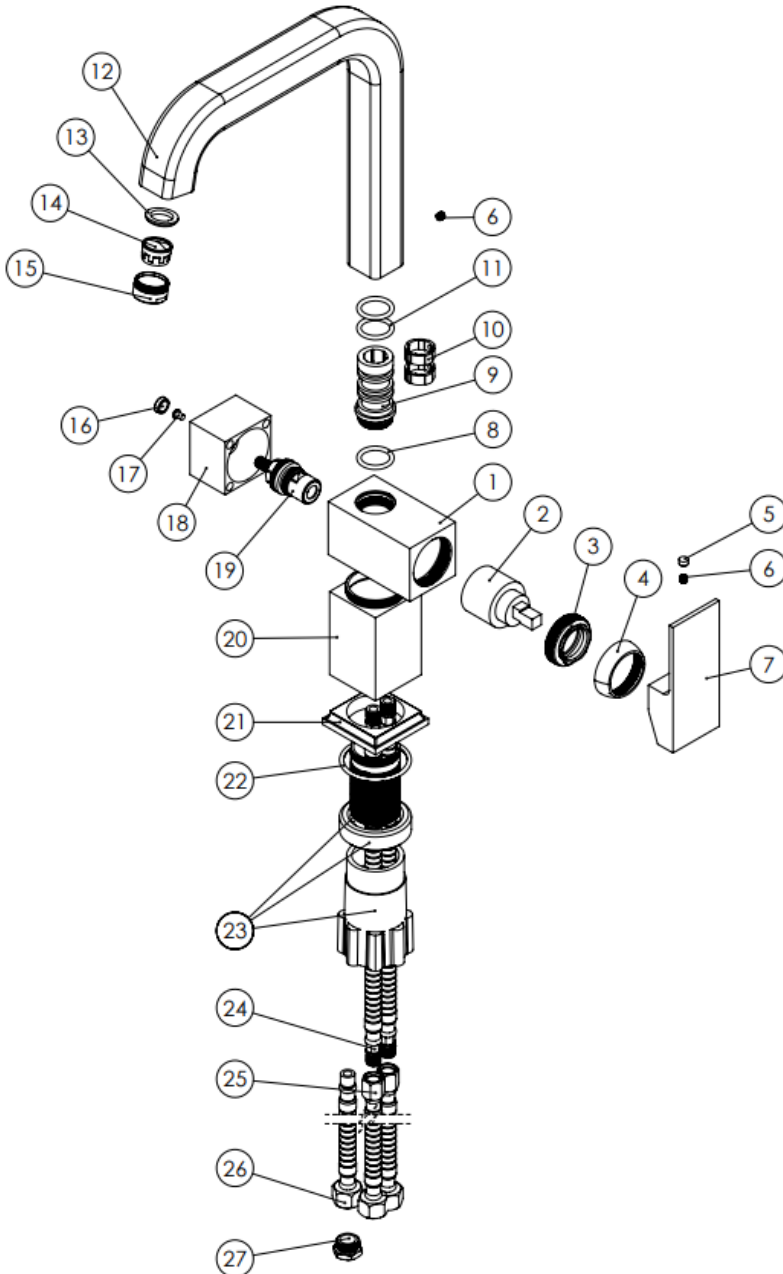

**MODEL NAME ATLANTIC DUAL-PURPOSE MODEL NUMBER 201100270005
KITCHEN**

Part List

No.	Item Number	Quantity used	No.	Item Number	Quantity used
1	304700000073	1	24	121000000027	2
2	120100000012	1	25	121000000040	2
3	120100000024	1	26	121000000014	1
4	310800000001	1	27	127100000002	1
5	121500000003	1			
6	120500000099	2			
7	305700000027	1			
8	120200000076	1			
9	317800000016	1			
10	123800000006	2			
11	120200000084	2			
12	302700000042	1			
13	120300000025	1			
14	121700000004	1			
15	313700000002	1			
16	121500000002	1			
17	120500000085	1			
18	305700000052	1			
19	123400000005	1			
20	302400000001	1			
21	306500000002	1			
22	120200000082	1			
23	123500000006	1			