

**MODEL NAME ATLANTIC SPRING
KITCHEN SINK TAP MIXERS**

MODEL NUMBER 201100290005

Description

High heat and pressure resistant ceramic cartridge
With direct connection to water treatment machine
Water saving perlator
Easily cleanable
Fast and easy installation
Ergonomic structure
Cartridge size: 35mm
%100 QC
Higher flexibility
Spring kitchen sink tap mixers type model, dual-purpose

Scale Drawing

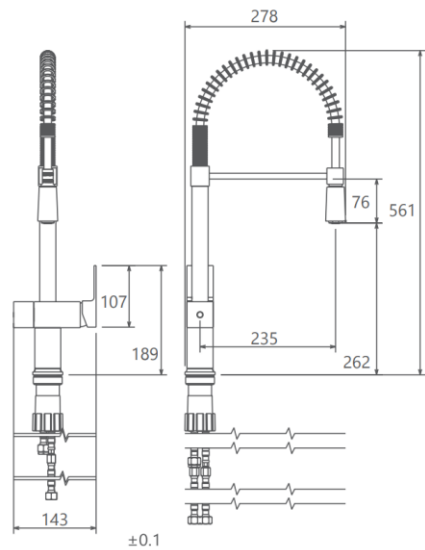

**MODEL NAME ATLANTIC SPRING
KITCHEN SINK TAP MIXERS**

MODEL NUMBER 201100290005

Exploded Drawing

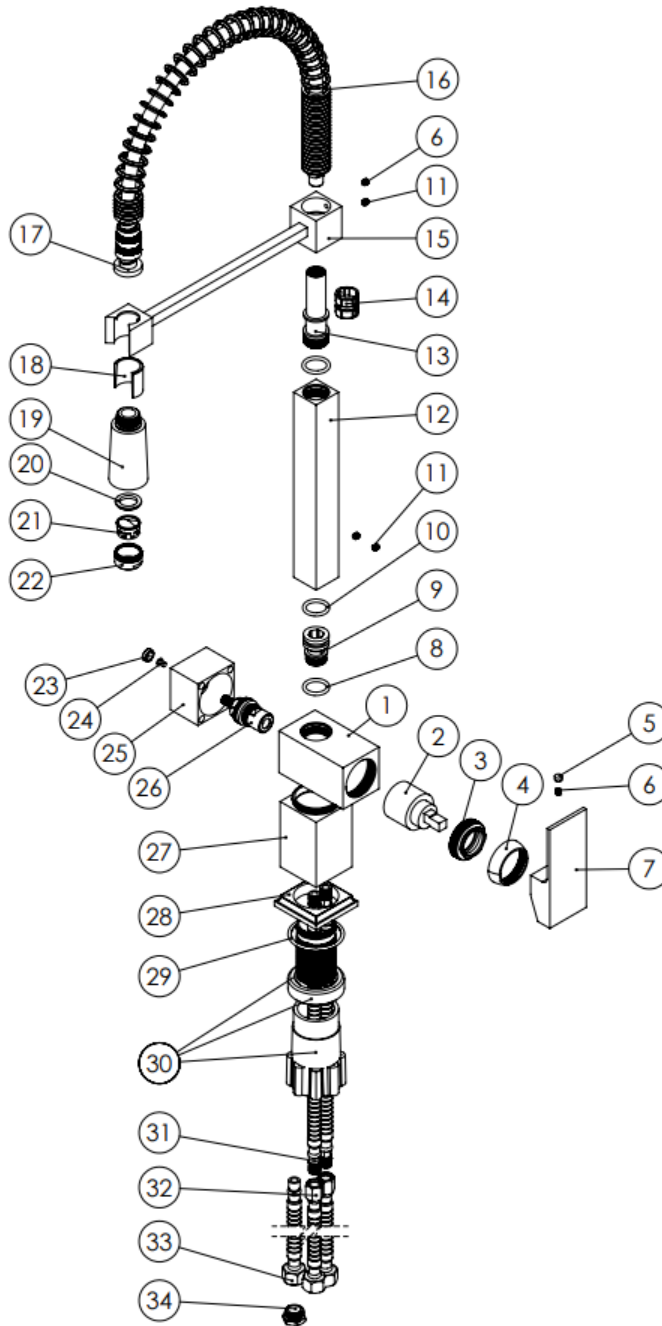

MODEL NAME ATLANTIC SPRING KITCHEN SINK TAP MIXERS **MODEL NUMBER 201100290005**

Part List

No.	Item Number	Quantity used	No.	Item Number	Quantity used
1	304700000073	1	24	120500000085	1
2	120100000012	1	25	305700000052	1
3	120100000024	1	26	123400000006	1
4	310800000001	1	27	302400000001	1
5	121500000003	1	28	306500000002	1
6	120500000099	4	29	120200000082	1
7	305700000027	1	30	123500000005	1
8	120200000043	1	31	121000000027	2
9	317800000039	1	32	121000000040	2
10	120200000074	2	33	121000000014	1
11	120500000100	1	34	127100000002	1
12	302700000158	1			
13	122000000013	1			
14	123800000006	2			
15	308400000001	1			
16	309600000005	1			
17	121000000002	1			
18	122100000033	1			
19	312400000001	1			
20	120300000025	1			
21	121700000004	1			
22	313700000002	1			
23	121500000002	1			